

State of California
Business, Consumer Services and Housing Agency
Department of Housing and Community Development
Division of Codes and Standards



MOBILEHOME PARK INSPECTION OPERATOR INFORMATION BOOKLET

- * ***Contains Important Information For Operators of Mobilehome Parks Regarding Inspections, Violations, and Code Requirements.***

- * ***Please read about the upcoming inspection of your mobilehome park.***

- * ***After the mobilehome park inspection is completed, keep this booklet as a reference guide of common park responsibilities.***

Important Information for Operators of Mobilehome Parks About Inspections, Violations, and Code Requirements

Notice of Planned Inspection

California Health and Safety Code Section 18400.1, amended and effective 1/1/2000, requires mobilehome/manufactured home enforcement agencies to enter and inspect mobilehome parks to ensure enforcement of the Mobilehome Parks Act. The California Department of Housing and Community Development (HCD), Division of Codes and Standards will be conducting an inspection of the general areas, buildings, equipment, and utility systems of your mobilehome park, as well as each individual lot. A NOTICE OF PLANNED INSPECTION has been posted in a conspicuous location within the mobilehome park to inform your park residents of the upcoming inspection. The inspection will be conducted thirty to sixty days from the "Date Posted" shown on the NOTICE OF PLANNED INSPECTION. You have been referred to an inspection orientation video on our website.

Each resident will receive a letter from this Department notifying them of the inspection. Information regarding this upcoming inspection is available on our website, www.hcd.ca.gov and may also be viewed on *YouTube*.

Using this Booklet

The Department makes this booklet available to the operators or their representatives and contains important information about the inspection, violations, and related issues. The Department encourages operators of manufactured home/mobilehome parks to review the information on how to inspect your park facilities for possible violations prior to the inspection, many of which can be easily corrected before the Department's inspection. Park violation information begins on page four (4) of this booklet.

Note: The terms "Unit" and "MH-unit" used throughout this booklet are the referenced terms for manufactured homes, mobilehomes, multi-unit manufactured housing, and recreational vehicles as defined in the California Code of Regulations, Title 25, Division 1, Chapter 2, Article 1, Section 1002. For clarity they are reprinted below.

MH-unit: A manufactured home, mobilehome, or multi-unit manufactured housing.

Unit: A manufactured home, mobilehome, multi-unit manufactured housing, or recreational vehicle.

Be aware, this booklet provides information that refers to state laws and regulations. However, the information is a guide and is not the actual laws and regulations.

Booklets for Residents

The resident booklet is similar in design to the operator booklet and provides much of the same information contained in this booklet except it lists common violation information.

Scope of Inspection

The inspection will include the park's general areas, buildings, equipment and utility systems for proper maintenance and code compliance. Inspection of lots will include proper identification of lot lines, park owned utilities, utility connections at each home, accessory structure maintenance, separation, setback requirements, use of extension cords for pursuant wiring, fire hazards, rubbish, and other health and safety issues. The inspection may also include verification of the current registration of the MH-units owned by the park.

Request to Accompany Inspector

Upon request and approval by the assigned park inspector, one park representative and one resident representative may accompany the inspector during the initial inspection. The privilege of attending the inspection is at the sole discretion of the inspector.

Interior Inspections

Under normal circumstances, the Department will not be entering homes while conducting the inspection. The inspector may request entry only when conditions observed from the exterior of a home suggest a potential hazard or substandard condition exists within the home. However, the right to grant or refuse entry into a home is at the discretion of the resident or homeowner.

If the inspector requests and is permitted entry, the resident or homeowner will be asked to sign a statement acknowledging permission. The granted permission will be for the inspector's entry only. If entry is refused, the inspector may seek a search warrant in order to gain entry based on the possible existence of a hazard or substandard condition.

All park buildings and equipment enclosures shall be accessible for interior inspection at the time of the planned inspection.

Preparing for Inspections

In preparation for the upcoming inspection you should perform the following steps:

1. Properly identify the lots by letters, numbers, or street address numbers. The lot identification must be in a conspicuous location facing the roadway. If the lot identification is to be installed on the wall surface of a unit, the wall surface nearest the roadway shall be used. See California Code of Regulations, Title 25, Section 1104(a).
2. Permanently mark all corners of each lot. See California Code of Regulations, Title 25, Section 1104(c). Please note lot lines shall not be created, moved, shifted, or altered without written authorization of the registered owners of the units on the lots affected, if any, and by a permit from the enforcement agency in accordance with Title 25, section 1105. The Department will also accept the identification of

recognizable lot line locations verifiable through a recorded assessors map or similar legal document.

3. Post all local and park emergency information, as well as the name, address, and phone number of the Mobilehome Ombudsman or post the Mobilehome Ombudsman poster in a conspicuous location. See California Code of Regulations, Title 25, Section 1122, and the California Civil Code, Section 798.29.
4. Prior to the preinspection conference, you should have received a letter from the Department requesting a list of the name of each park resident, their mailing address, evidence of current registration, and the registered owners name and address, if different from the resident. If you have not already provided this information, the inspector can collect this information from you at the preinspection conference.
5. Instruct all residents to display current registration decals or license plates on the exterior of manufactured homes and mobilehomes. In lieu of an exterior decal or plate, current registration documents may be presented to the Department inspector or temporarily displayed on the inside of a window in the resident's home until the inspection of their lot or the park is complete.
6. Advise residents to read their Mobilehome Park Inspection Resident Information Booklet, and inspect their own lots for violations, and take corrective action prior to the scheduled inspection.
7. An inspection video is available to both the park and its residents and provides information on the inspection process. This video may be viewed on the Department website, www.hcd.ca.gov, or on **YouTube**.
8. Refer resident questions about the inspection and booklet to the assigned inspector.
9. Review how to conduct your own inspection commencing on page 4.

Inspector Identification

The Department of Housing and Community Development Inspector will be wearing a blue vest bearing the Department logo which incorporates the State Seal. The Department's inspectors also carry identification cards with their facial photograph. To ensure the privacy and safety of park residents, you may ask the inspector for identification.

Administrative and Legal Actions

Subsequent reinspections will be conducted throughout the mobilehome park maintenance inspection process until all park and resident violations have been corrected. Failure to abate all violations may result in the suspension of the park's Permit to Operate. Should the permit be suspended, it would be illegal for you to charge or accept rent for lots in the park or for rental mobilehomes or RV's you may own in the park pursuant to Health and Safety Sections 18214 and 18500. Legal action to obtain a misdemeanor conviction for failure to comply with an issued Notice of Violation is avoidable. Such action is taken only when a park operator or resident refuses to make corrections of conditions presenting hazards to occupants of the park, homes, or the general public.

Additional Information

For additional information contact the HCD inspector assigned to your area.

Notice of Violation

Violations observed during the initial inspection will generate a Notice of Violation letter which the park will receive for those items that are the park responsibility; the residents will receive a violation letter for those violations observed on their lot or their manufactured/mobilehome. The park will not be notified of the residents' violations and the park violations will not be disclosed to residents until after the first reinspection has been performed. Should resident violations remain uncorrected after the first reinspection, a copy of the residents' Final Notice of Violation will be provided to the park operator or responsible person pursuant to Health and Safety Code 18420(b)(1) and should park violations remain, they will be posted in a conspicuous location in the park.

Time Allowed for Correction

The initial Notice of Violation allows sixty (60) calendar days from the date reflected on the Notice of Violation for the park and its residents to correct the violations. However, violations that present an imminent health and safety hazard representing an immediate risk to life, health, or safety require immediate correction.

Reinspections

After the expiration of the initial time allowed to correct violations, the Department will conduct a reinspection to verify compliance with any issued Notice of Violation. Should uncorrected violations remain after the first reinspection, a Final Notice of Violation letter will be sent to the park and those residents who have not yet abated their violations. This letter allows an additional 30 days from the date on the letter to correct any outstanding violations.

Posting of Park Responsible Violation(s)

At the conclusion of the first reinspection, the HCD inspector will post a copy of the park's uncorrected violation(s) in a conspicuous location in the mobilehome park. The park's posted Final Notice of Violation shall only be removed by the Department after the violation(s) have been corrected.

Items for the Park Operator to Inspect

Prior to the Department's inspection, the park owner or operator may eliminate many violations by inspecting the park grounds, facilities, and equipment and making appropriate corrections. The Department will cite the following conditions if found to endanger life, limb, health, and safety of the public and occupants. Use the following information as a guide for your inspection.

1. Permits

Permits must be obtained for the construction or alteration of any structure, electrical, mechanical, plumbing, fuel gas, or fire protection equipment or system in the park. Correction of some violations noted in this booklet may require a permit. If you have questions, check with the enforcement agency.

2. Posting Emergency Information

- a. The park is required to post an "Emergency Information Bulletin," listing the correct telephone numbers for the Fire Department, Police Department or Sheriff's Office, Park Office, the responsible person for operations and maintenance, enforcement agency, locations of the nearest fire alarm box (when available), park address (street or highway number), and nearest public telephone.
- b. The park is required to post the Department issued Permit to Operate in a conspicuous place.
- c. The park's Emergency Preparedness Plan (EPP) and evacuation map must be made available to the park's residents upon request.

3. Manufactured Home/Mobilehome/Recreational Vehicle (Unit) Lots

Park lots should be inspected for identification to ensure:

- a. All lot corners are identified by permanent corner markers visible at grade and installed in a manner that does not create a hazard. Permanent markers shall be as prescribed in Title 25, Section 1104 (c), and may include rebar driven eighteen inches (18") into the ground, pipe, and saw cuts in curbs.
- b. All lots are identified with letters, numbers or, street address numbers. The lot identification must be in a conspicuous location facing the roadway. If the lot identification number is installed on the wall surface of a unit, the surface nearest the roadway is to be used.
- c. Lot lines shall not be created, moved, shifted, or altered without the written authorization of the registered owners of the units on the lots affected, if any, and a permit is from the enforcement agency in accordance with Title 25, Section 1105.
- d. The total number of lots in the park shall not exceed the total number of mobilehome or RV lots reflected on the annual Permit to Operate respectively. Procedures are available to amend the Permit to Operate to reflect current usage.

4. Animals in the Park

Inspect the park for loose domestic animals. Dogs or other domestic animals and cats (domestic and feral) shall not roam at large (free) in the park. Lots and park

areas are to be maintained reasonably clean of domestic animal waste.

5. Grading

Grade or fill common areas, lots, and roadways with depressions or low spots so water will not accumulate.

6. Fire Safety

The park should be inspected for fire safety to ensure:

- a. The existing fire suppression equipment, such as hydrants and hose reels, has been tested and certified and is in operable condition.
- b. In addition to connection to the unit, each lot has a three-quarter inch (3/4") hose bib for fire suppression in addition to the connection for the unit.
- c. Accumulations of refuse, garbage, rubbish, debris, such as paper, leave, dry grass, weeds, scrap wood material, or other combustible materials are removed.
- d. In parks constructed after September 15, 1961, streets must be at least 32' in width to allow parking on one side of the street, and 40' to allow parking on both sides of the street.
- e. To allow on street parking in parks constructed prior to September 15, 1961, streets must be at least 22' in width if parking is allowed on one side of the street, and 30' in width to allow parking on both sides of the street.
- f. To retard the spread of any fire, units are to maintain a minimum of six feet (6') from a unit, permanent buildings, combustible accessory buildings, structures, or building components on adjacent lots, and maintain a minimum three feet (3') from lot lines not bordering a park roadway or common areas.

7. Approval Insignia Required on Rented Homes

A manufactured home constructed on or after June 15, 1976 and offered for rent, sale or lease must bear a HUD Label. A mobilehome manufactured between the dates of September 1, 1958 and June 15, 1976 that is sold, offered for sale, rented, or leased within this state must bear the Department's Insignia.

If a manufactured home does not bear the HUD label, the owner must apply to HUD's Office of Manufactured Housing Programs at (202) 708-6423 or e-mail a <http://www.hud.gov/offices/hsg/sfh/mhs/mjslabels.cfm>. If the unit is a mobilehome, the owner of the mobilehome must apply to the Department for an inspection of the mobilehome to obtain an insignia. The label or insignia represents that the unit has met the minimum construction requirements in effect

Note: A Recreational vehicle or park trailer which is rented or leased must bear a label or insignia indicating the manufacturer's compliance with the appropriate

ANSI Standard, or a Department insignia issued prior to January 1, 1999. It will not be possible to obtain a replacement insignia for a recreational vehicle, or park trailer, or obtain an insignia by inspection from the Department for a recreational vehicle manufactured on or after January 1, 1999.

8. Park Electrical System

The general park electrical distribution system should be inspected to ensure:

- a. All breakers are labeled and identified.
- b. The support poles for overhead systems are adequate.
- c. There is at least an eight foot (8') clearance between the overhead conductors and the unit's roof.
- d. At least twelve feet (12') is provided over areas accessible to pedestrians only.
- e. At least twelve feet (12') is provided over driveways.
- f. The underground conduit is properly maintained.
- g. The exterior equipment is weatherproof and that there are no exposed internal parts.
- h. The electrical equipment and circuitry is clearly identified and permanently marked identifying the space number or use.
- i. Exposed conductors are protected against physical damage.
- j. The lot electric service equipment is accessible for maintenance and not locked.

9. Lot Electrical Service Equipment

The lot electrical service equipment supplying power to each unit should be inspected for adequacy and safety to ensure:

- a. The lot electrical service equipment receptacles and/or breakers or fuses are rated in accordance with the rating of the mobilehome unit's electrical system.
- b. The lot service equipment overcurrent protection device is the approved size and type and installed in an approved manner.
- c. The lot electrical service equipment, if exposed to the weather, has a weather-tight enclosure approved for damp or wet locations.
- d. Park or lot electrical service equipment with exposed electrical parts are provided with a cover. All exposed parts are covered and unused openings are plugged.
- e. The wiring which supplies power to the lots has the capacity to properly supply

the unit installed on the lot.

- f. The lot electrical service conductors are the approved size and type for the demand required by the unit on the lot.
- g. The grounding of the lot electrical equipment (pedestal, receptacle, junction box, etc.) does not have loose or unprotected ground wires, particularly at the grounding rod or water pipe.
- h. The lot electrical equipment (pedestal, receptacle, junction box, transformers) is protected against physical damage by posts, fencing or other barriers as approved by the enforcement agency.
- i. The box-type lot electrical equipment (disconnect/receptacle plug-in type) is secured to a 4 x 4 redwood or pressure treated post (or equivalent) in a concrete pad. Replace deteriorated or broken posts with a post set into the earth not less than two feet (2') and stabilized by a three and one half inch (3 ½ ") thick concrete pad extending at least six inches (6") on all sides of the post.
- j. Unimpeded access is provided to the lot service electrical pedestal at all times.
- k. The lot electrical service equipment does not have broken or missing receptacles.
 - i. Remove or replace receptacles and install missing receptacles.
- l. Mobilehomes and recreational vehicles with power cords must be plugged into a receptacle and shall not be wired directly.

10. Park Lighting

Park lighting should be inspected to ensure:

- a. Roadways and walkways within the park have adequate and operable lighting during the hours of darkness.
- b. Sufficient artificial light is provided to adequately illuminate every recreational building, laundry, and buildings containing toilets, public showers, and the area of the park when in use during the hours of darkness.

11. Park Gas System

The entire park gas system should be inspected and repaired as needed to ensure:

- a. The park gas system, its equipment, and lot gas service equipment, is protected against potential physical damage, such as vehicle traffic.
- b. Each lot shall have a gas shutoff valve installed in a readily accessible location upstream of the lot gas outlet or gas meter.
- c. The gas shutoff valve is located on the gas rise outlet at a height not less than six inches (6") above grade.

- d. The lot gas connection from the mobilehome to the lot gas meter is by an approved flexible gas connector listed for manufactured home/mobilehome use and for exterior use.
- e. The total of all liquid petroleum gas (LPG) tanks on the lot do not exceed sixty (60) gallons without a permit.
- f. The gas meter is adequately supported by a post and bracket, or other approved means providing equivalent and independent support and not by the gas piping.
- g. LPG tanks are secured to prevent accidental overturning.
 - 1. When installed in a flood zone, the LPG containers are to be anchored to prevent flotation.
- h. Ensure there is adequate clearance around the LPG vessel installed lot. Minimum clearances from the filling connection or vent to sources of ignition, direct vent appliances, and mechanical ventilation air intakes:
 - 1. Ten feet (10') minimum for purposes of filling.
 - 2. Five feet (5') minimum to pressure relief valve.
 - 3. The pressure-relief valve is directed away from the openings in buildings below the valve
 - 4. The tank is not located in areas with less than 50% open for ventilation.

Note: Lot electrical service is not considered a source of ignition.
- i. The lot gas riser, shut-off valve, and/or meter is not located under a unit, or habitable cabana, RV, accessory building or structure, or is in an inaccessible and/or unvented location.
- j. Unused lot gas outlets, even with a shut-off valve, are capped or plugged to prevent accidental discharge of gas.
- k. Any and all gas leaks within any part of the park's gas system are repaired immediately.

12. Fuel-Oil Equipment

Fuel oil tanks and equipment belonging to the park and on individual lots should be inspected and repaired as needed to ensure:

- a. Protect park fuel tank(s) and its equipment against potential physical damage such as vehicle traffic.

- b. Tanks used for supplying fuel oil to a unit with oil-burning appliances should not be larger than 150 gallon capacity.
- c. No more than two (2) tanks with a combined maximum capacity of 150 gallons shall be installed on a lot.
- d. Tanks not to be located closer than five feet (5') to a lot line or to the nearest side of a roadway.
- e. Tanks shall not to be located in an area accessible to motor vehicles.
- f. Tanks elevated above ground to be maintained on rigid, noncombustible supports of adequate size to support the tank when filled.
- g. Tanks to be installed on concrete foundations or footings to prevent movement or settling.
- h. Securely fasten tanks to the supporting frame.
- i. A shutoff valve to be located immediately adjacent to the gravity feed connection of a tank in the supply line to the unit.
- j. Fuel oil connectors from the tank to the unit are to be brass or copper tubing or approved flexible metal hose not smaller than three-eighths inch (3/8").
- k. Every tank shall be adequately designed, installed, vented, and maintained.

13. Park Sewer Drain System

The park sewer drain system is to be inspected to ensure:

- a. Unused openings, such as lot inlets and clean-outs, are capped or plugged so the system is maintained leak free and gas tight. Leaks in the park sewer drain system must be repaired immediately.
- b. Sewer system vents, when installed, are maintained with a minimum two inch (2") interior diameter vent extended a minimum of ten feet (10') above grade. Vents must be adequately supported and secured.

14. Park Water System

The park water system should be inspected to ensure:

- a. Each lot is provided with a water service outlet delivering potable water.
- b. The park water system is free from leaks. Leaks within the park's water system must be repaired immediately.
- c. The lot water service equipment is protected against vehicle damage by posts, fencing, or other barriers approved by the enforcement agency.

15. Fire Safety

The park should be inspected for fire safety to ensure:

- a. Verify existing fire suppression equipment, such as hydrants and hose reels, has been tested and certified and is in operable condition.
- b. In addition to the mobilehome water inlet, each lot is to have a three-quarter inch ($\frac{3}{4}$ ") hose bib for fire suppression.
- c. Accumulations of refuse, garbage, rubbish, debris, such as paper, leave, dry grass, weeds, scrap wood material, or other combustible materials removed.
- d. In parks constructed after September 15, 1961, streets must be at least thirty-two feet (32') in width to allow parking on one side of the street, and forty feet (40') to allow parking on both sides of the street.
- e. To allow on-street parking in parks constructed before September 15, 1961, streets must be at least twenty-two feet (22') in width if parking is allowed on one side of the street, and thirty feet (30') in width to allow parking on both sides of the street.
- f. To retard the spread of any fire, MH-units are to maintain a minimum of six feet (6') from a unit, permanent buildings, combustible accessory buildings or structures, or building components on adjacent lots, and maintain a minimum three feet (3') from lot lines not bordering a park roadway or common areas.

16. Grading

Grade or fill common areas, lots, roadways with depressions or low spots where water may accumulate.

17. Park Buildings and Associated Equipment

Park buildings and equipment should be inspected to ensure:

- a. The clubhouse interior, storage rooms, kitchens, offices, toilets, and showers should be inspected for maintenance, health, and safety issues.
- b. The exterior of the clubhouse outdoor kitchens/barbeque areas, pool areas, and outdoor showers should be inspected for maintenance, health and safety issues.
- c. The laundry room should be inspected for maintenance and safety issues.
- d. The laundry room washers and dryers should be inspected for maintenance and safety issues.
- e. The park car wash area, if any, should be inspected for maintenance and safety issues.

- f. The park swimming pool equipment room, if any, should be inspected for maintenance and safety issues.

18. Miscellaneous Items

- a. Fences to be maintained in good condition and structurally sound.
- b. Retaining walls to be maintained in good condition and be structurally sound.
- c. Storage buildings and sheds are not to be used for human habitation.
- d. Tree limbs and shrubbery is not to be in contact with the MH-unit roof.

Items for the Park Resident to Inspect

Prior to the Department's inspection, park residents may eliminate many violations by inspecting their lots and MH-units. The following is a list of commonly found resident violations. The Department will cite these conditions if found to endanger life, limb, health or the safety of the public and occupants. The following information is a guide for the resident inspection.

1. Registration

A MH-unit is to be currently registered and is to display the appropriate registration, license plate, or local property taxation decal. Display evidence of the current registration or local property taxation status, or provide evidence to the park management or to the Department inspector.

2. Permits

If any of the following changes have been performed without a valid permit, you are encouraged to obtain a permit prior to the Department's park-wide inspection in order to avoid possible penalties:

- a. Installation, construction, or alteration of:
 - i. any accessory building, or structure, including porches, awnings, or room additions;
 - ii. any storage cabinet exceeding 120 square feet;
 - iii. any electrical, mechanical, or plumbing equipment
 - iv. any fuel gas equipment
- b. Alteration of a MH-unit requires a permit from the Department of Housing and Community Development.
- c. Installation of a MH-unit within the park requires a permit from the enforcement agency.
- d. Prior to construction of any project, verify with the Department if the park is

located in a Fire Hazard Severity Zone or Wildland Urban Interface Fire Area (WUI) as restrictive construction standards may apply to your project.

3. Emergency Exiting

- a. To ensure safe exiting during an emergency, remove any obstruction which would prevent exterior doors from opening.
- b. Remove hasps and padlocks installed on the exterior of the home. In the event of an emergency, exit doors locked by a padlock or hasp prevent the door from being opened from the outside and will trap occupant inside the Unit.

4. Debris and Combustible Storage

Inspect the areas under and around the Unit and remove any accumulation of refuse, garbage, rubbish, combustible debris such as paper, leaves, dry grass, scrap wood, and other combustible materials.

5. Animals

Domestic animals, including cats, shall not roam free in the park and the lot shall be maintained reasonably clean of domestic animal waste.

6. Appliances

- a. Appliances located outside of a unit must be protected from the weather. Locating them under an awning is not acceptable. They must be in some type of enclosure.
- b. Electrical power to an outdoor appliance is to be provided only through a permanent wiring means; extension cords are not permitted.

7. Multiple Units on a Lot

- a. Only one unit may be installed on an individual lot.

Exception: A self-propelled recreational vehicle or truck-mounted camper may be parked on the lot when it is used as a frequent means of transportation. The self-propelled unit may not be connected to the utilities or interconnected to the other unit on the lot.

- b. A camper, intended for truck mounting, may not be removed from the truck and placed on the lot. A truck camper shell is not considered a camper.

8. Mobilehome or Recreational Vehicle Setbacks from Lot Lines

A MH-unit must have the required three foot (3') clearance from all lot lines. If the unit is placed within three feet (3') of a lot line, relocation may be required.

Exception: A unit bordering a roadway or common area may be installed up to the lot line which borders the roadway or common area.

9. Substandard Manufactured Home/Mobilehome or Recreational Vehicle (Unit)

A Unit in substandard condition may be ordered removed from the park unless the substandard conditions are repaired. Substandard conditions may include: but are not limited to:

- a. Structural hazards such as deteriorated floors, buckled walls, deteriorated roof members, etc.
- b. Electrical hazards include bare wires, unprotected cables or conductors, open splices, etc.
- c. Improper plumbing to include leaking fixtures.
- d. Mechanical hazards include unvented or improperly vented gas appliances.
- e. Faulty weather protection such as leaks in the roof, broken windows, damaged siding, etc.

10. Power Cords

A large rubber-coated type electrical cord used to power a Unit should be inspected to ensure:

- a. The covering on the cord is not cracked or deteriorated.
- b. The area of the plug is not damaged or pulling away from the cord.
- c. The cord is not cut or spliced.
- d. The power cord plug has not been removed and the cord is not directly wired to the park electrical service.
- e. The power cord is listed and approved for manufactured home/mobilehome or recreational vehicle use.
- f. The cord is not buried in the ground or encased in concrete.
- g. The Unit does not have more than one power supply cord.
- h. An approved adapter, not more than 12 inches (12") in length, in use prior to

July 7, 2004 will be allowed its continued use provided it is installed and maintained in a safe operating condition.

- i. The power cord is not rated less than the electrical load of the Unit. Example: If the Unit's cord is rated at 30 amperes and the Unit load is 50 amperes, the 30 amp cord is not allowed.
- j. The Unit's lot pedestal amperage does not exceed the power supply cord or feeder rating.

11. Feeder Assemblies

A Unit that is electrically connected to the lot electrical service by a flexible metal conduit (feeder assembly), should be inspected to ensure:

- a. The conduit is not buried or in contact with the ground.
- b. The conduit provides continuous, complete protection of the electrical conductors inside.
- c. No more than one "feeder assembly" is utilized to supply power to the Unit.
- d. The feeder assembly is not rated less than the electrical load of the Unit. Example: If the Unit's feeder assembly is rated at 30 amperes and the Unit load is 50 amperes, the 30 amp feeder assembly is not allowed.

Exception: An air-conditioning unit and/or a circuit to an accessory structure may be permanently wired to the lot pedestal provided the lot service can accommodate the additional load. A permit is required for this installation.

12. Wiring Methods

The general electrical conditions affecting the Unit should be inspected to ensure that:

- a. Extension cords cannot be used in lieu of permanent wiring.
- b. Appliances cannot be installed outside the Unit; the equipment should be installed inside a structure using approved wiring methods.
- c. The cables and conductors for electrical wiring installed outside a Unit are protected against physical damage by installing the wiring in conduit.
- d. The electrical equipment installed outdoors is approved for wet or damp locations.
- e. All the parts or components of the electrical equipment of the Unit, or equipment for accessory uses, are installed so that no energized parts are exposed.

- f. The lot electrical service equipment is accessible at all times. Remove any storage or permanent construction obstructing access to the lot electrical service equipment.
- g. The Unit is electrically grounded to prevent electrical shock.

Note: If you believe that one or more of the above conditions affect the electrical system of the MH-unit, it is recommended you consult a licensed electrician for assistance and correction of the condition. Permits are required prior to the installation of any electrical wiring.

13. Gas Meter

The gas meter regulator and shutoff valve provided on the lot must be accessible at all times and be in a well-ventilated location.

14. Gas Connectors

Inspect the condition of the gas system connector. It should be a single flexible gas connector not over six feet (6') in length, listed for exterior use, and not buried or otherwise in contact with the ground.

15. Propane Gas Tanks

When a Unit is supplied by external liquefied petroleum gas (LPG) tank(s), inspect the tank(s) to ensure:

- a. The lot gas connection from the Unit to the lot gas meter is by an approved flexible gas connector listed for use for a manufactured home/mobilehome or RV, and is listed for exterior use.
- b. The total of all tanks on the lot does not exceed one hundred twenty-five (125) US gallons. If the total exceeds 125 US gallons, the more restrictive provisions of the Unfired Pressure Vessel Safety Orders, California Code of Regulations, Title 8, Chapter 4, Subchapter 1, would apply.
- c. Secure LPG vessels to prevent accidental overturning by securing to the Unit's hitch, a support post, or other approved means.
- d. There is adequate clearance around the LPG vessel installed on the lot. Minimum clearances from the filling connection or vent to sources or ignition, direct vent appliances, and mechanical ventilation air intakes:
 - i. Ten feet (10') minimum for purposes of filling.
 - ii. Five feet (5') minimum to pressure relief valve and the valve must be directed away from the openings in building below the valve.
 - iii. The tank cannot be located in areas with less than 50% open ventilation or under the Unit.

Note: Lot electrical service is not considered a source of ignition.

- e. LPG vessels are not stored inside or underneath the Unit, a habitable accessory building, or an accessory structure that is not open more than 50% for ventilation. Except personal portable appliances, such as barbeques, may be stored in enclosed areas.
- f. When installed in a flood zone, the LPG containers should be anchored to prevent floatation.

16. Gas Lines

If the gas piping system has been extended to reach the park's gas inlet, the extension pipes must be supported. Support the pipe with metal hangers at maximum four foot (4') intervals.

17. Water Heaters

Inspect the Unit's water heater for minimum safety requirements to ensure:

- a. The gas water heater is properly vented to the exterior of your home.
- b. Access to the water heater is unobstructed.
- c. The water heater compartment is weather tight and protected from the rain, elements, etc.
- d. The water heater has a functional pressure temperature relief valve. Extend the valve piping to the underside of the MH-unit with piping, suitable for use with hot water, without threads on its ends, the same size as the valve opening. It must exit under the MH-unit.
- e. The water heater has adequate openings into the compartment for combustion air.
- f. The water heater has the required clearances from its vent at the ceiling of the compartment, and has sufficient clearances from its sides to the combustible walls of the compartment.

Note: If there is a problem with the water heater or its installation, refer to the water heater manufacturer's recommendations or consult a licensed plumber.

18. Sewer Drains

The sewer drain connector on the Unit should be inspected to ensure:

- a. The sewer drain is gas tight and leak free.
- b. The sewer drain is sloped to drain a minimum of one-eighth inch (1/8") per

foot

- c. The sewer drain is supported every four feet (4').
- d. The drain is constructed of a minimum schedule 40 ABS plastic approved for drain and waste use.
- e. The connection to the lot sewer inlet contains a flexible connector.
- f. Recreational vehicles connected to the lot drain in a park for more than three (3) months must have a sewer drain connection consisting of a minimum of schedule 40 ABS plastic piping approved for drain and waste use. A flexible recreational vehicle hose-type drain is only acceptable as a temporary connection and is not approved as a permanent connection.
- g. All drain fixtures discharge into an approved sewer or septic system.

19. Water Supply Connector

Inspect the fresh water supply connector on the Unit to ensure:

- a. The fresh water supply connector on the Unit is leak free.
- b. The fresh water supply connector is made of a flexible material approved for potable water such as soft copper tubing not less than one-half inch (1/2") in diameter.
- c. Water conditioning equipment is installed in an approved manner. However, it requires a permit to install.

20. Exits

- a. Every exit door on the MH-unit has complying stairs, ramps or landing.

21. Stairways

Stairways at each required exit door are required to be safe and stable and should be inspected to ensure:

- a. The risers of stairways are a minimum of four inches (4") and do not exceed eight inches (8") in height. Risers should not vary by more than three-eighth inch (3/8").
- b. The stairway treads are not less than nine inches (9") in depth. Treads should not vary by more than three-eighth inch (3/8").
- c. The stairway width is not less than the width of the door.
- d. Recently constructed stairs must comply with the California Residential Code (CRC) requirements.

22. Stairway Landings

When an exterior door swings outward, a stairway landing is required and should be inspected to ensure:

- a. The landing is not lower than one inch (1") below the bottom of the Unit's door.
- b. The landing width and length is not less than the door width.

23. Guardrail for Porches and Decks

The guardrails for a porch or deck that is at least 30 inches (30") or more above grade should be inspected to ensure:

- a. The guardrail is at least 36 inches in height above the floor.

Note: Only new guardrails on an MH-unit need to be 42 inches (42") in height above the floor.

- b. The openings between intermediate rails are not more than nine inches (9") apart or more than four inches (4") if the porch or deck was constructed after July 7, 2004.
- c. The railings must be structurally sound.

24. Guardrail for Ramps

The ramp guardrail should be inspected to ensure:

- a. If the ramp is 30 inches (30") or more inches above grade, guardrails are installed on at least one side the ramp provided the other side is closed and extend the full length of the ramp.
- b. The guardrail is at least 36 inches (36") in height above the floor.
- c. The openings between intermediate rails are not more than nine inches (9") apart or more than four inches (4") if the ramp was constructed after July 7, 2004.
- d. The guardrails are structurally sound.

25. Handrails for Stairs

Any stairway to an MH-unit or accessory structure (deck, porch, room addition, etc.) more than 30 inches (30") above grade should be inspected to ensure:

- a. Stairs serving porches constructed more than 30 inches (30") above grade are equipped with intermediate rails spaced not more than nine inches (9") apart

or more than four inches (4") apart for stairs constructed after July 7, 2004.

- b. Handrails are not less than 30 inches (30") nor more than 34 inches (34") in height, as measured vertically from the nosing of stair treads, or not less than 34 inches (34") , nor more than 38 inches (38") in height if constructed after July 7, 2004.
- c. Handrails and intermediate rails are structurally sound. Secure any loose rails.

26. Skirting

The skirting of a MH-unit should be inspected to insure that the ventilation and access under the manufactured home/mobilehome ensure:

- a. When skirting is installed, an underfloor access panel is required. The panel must be 18 x 24 inches unobstructed by pipes, ducts, or other equipment that may impede access.
- b. A minimum 1½ square feet of ventilation is required for each 25 linear feet of skirting. The openings for ventilation shall be provided on at least two opposite sides as close to the corners as possible.
- c. Where wooden materials are used for skirting, any wood in contact or within six (6) inches of the earth must be decay and insect resistant wood, such as redwood.

27. General Accessory Structure Requirements and Awnings/Carports

Inspect general accessory structures to include awnings and carports to ensure that:

- a. Missing, damaged, or unanchored supports are repaired and are not more than 12 inches (12") off center.
- b. Combustible accessory structures should be a minimum three feet (3') from the lot line and not less than six feet (6') from any combustible unit, accessory building, structure, or building component on an adjacent lot. However, four inches (4") by four inches (4") nominal wood support posts on an aluminum awnings maybe located up to a lot line.
- c. Awnings and carports may extend to the lot line which borders a roadway.
- d. Wooden awnings and carports are free standing or have a permit for the attachment to the Unit.
- e. Metal awnings and carports do not project over the lot line.
- f. All non-combustible accessory structures must maintain a minimum three feet (3') from any Unit, accessory building, or structure on an adjacent lot.

- g. The structure is sound and in good condition.

28. Awning or Carport Enclosure

Awning enclosures are permitted for outdoor recreational use only and should be inspected to ensure:

- a. Any combustible structural components of the enclosure are a minimum of three feet (3") from a lot line except when the awning enclosure borders a roadway or common area.
- b. Awning enclosures or carports are to be free standing and not attached to the MH-unit.
- c. The structures cannot project over the lot line.
- d. Any electrical equipment installed is suitable for damp location.
- e. The enclosure is structurally sound.

29. Cabana (Room Additions)

Inspect room additions to ensure:

- a. The structure meets minimum standards for weather protection, electrical wiring, plumbing, and structural integrity.
- b. There is at least three foot (3') separation to the lot line.

30. Storage Cabinets or Sheds

Inspect storage cabinets or shed to ensure:

- a. The storage cabinet or shed is structurally sound.
- b. The structure is not installed within three feet (3') of a lot line except when the lot line borders a park roadway or common area.
- c. If the structure is noncombustible, the storage cabinet or shed may be installed up to the lot line provided there is a minimum three feet (3') separation to any structure on the adjoining lot.
- d. Storage sheds or cabinets exceeding 120 square feet in dimension require a permit from this Department. The total floor area of all storage cabinets on the lot does not exceed 120 square feet.

31. Miscellaneous Structures

Inspect garages, greenhouses, and storage buildings to ensure:

- a. The setback to the Unit is a minimum six feet (6'); however, garages and storage buildings with one hour firewall construction may be up to three feet (3') to the Unit on the same lot.
- b. Garages, greenhouses, and storage buildings constructed of combustible material are a minimum of three feet (3') from the lot line, except when the garage, greenhouse, or storage building borders a roadway or common area within the park.
- c. The structure is sound and in good condition.

32. General Accessory Building and Structures

- a. The structure is sound and in good condition.
- b. All non-combustible accessory structures must maintain a minimum three feet (3') from any Unit, accessory building, or structure on an adjacent lot.



Department of Housing and Community Development
 Division of Codes and Standards
MOBILEHOME PARK – NEW EXTERIOR SELF-SUPPORTING STAIRWAY
 2013 CALIFORNIA RESIDENTIAL CODE (CRC)

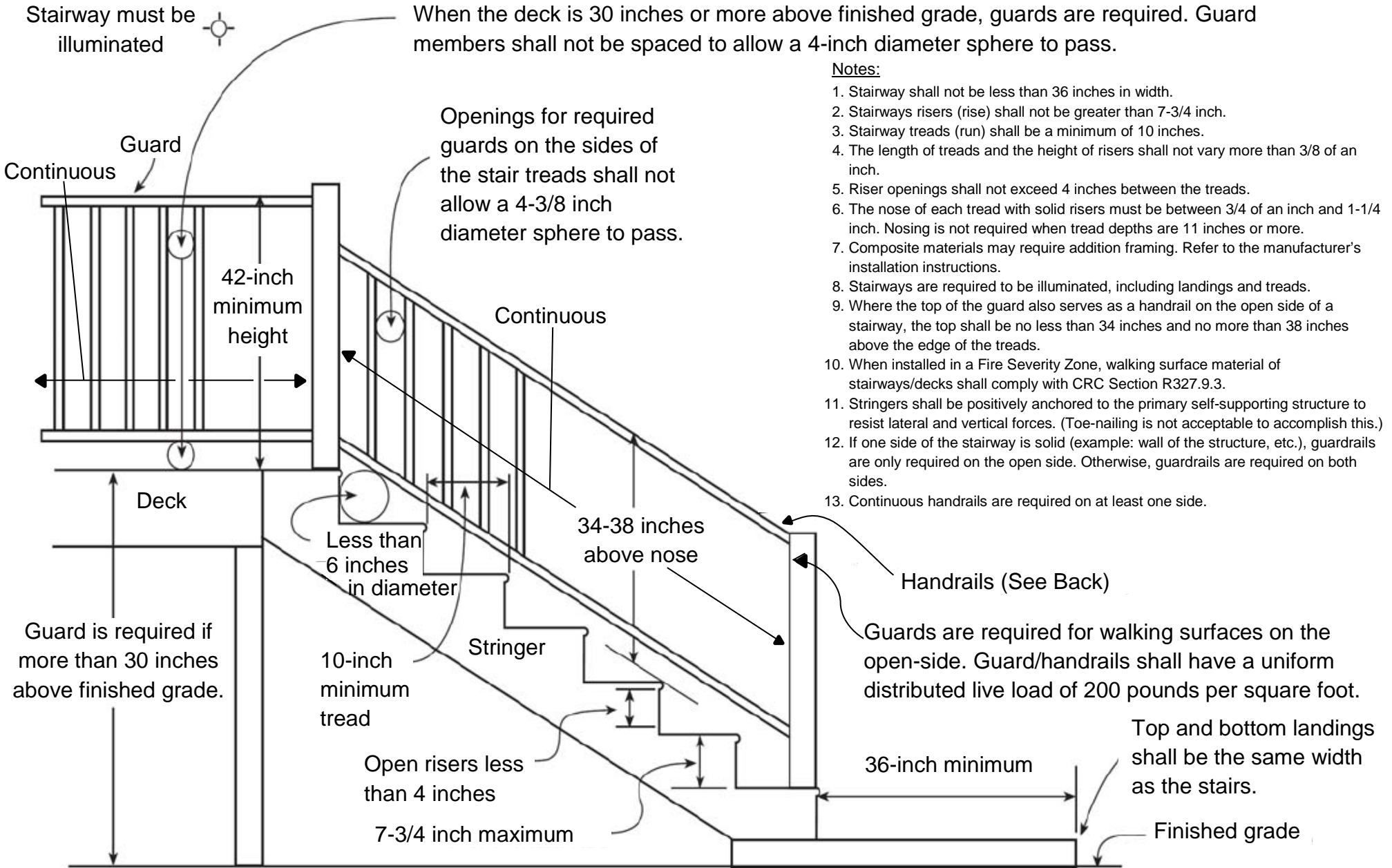

HANDRAILS

HANDRAIL GRIP EXAMPLES

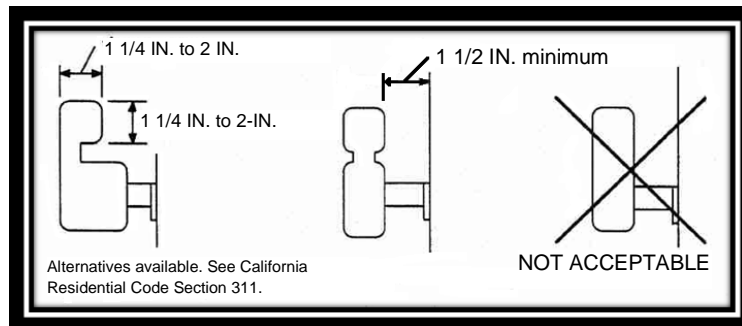

Handrails are required on at least one side when stairways have four or more risers.

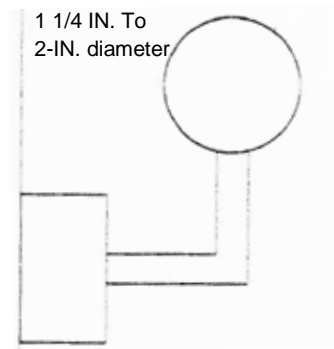

Type I (Circular)

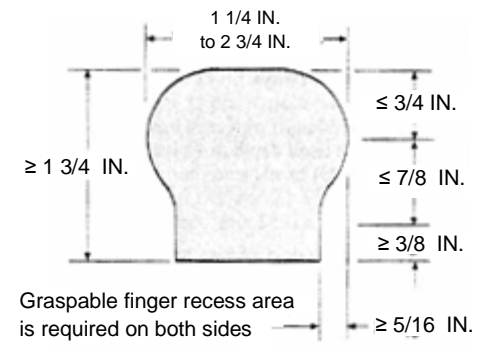

Type II (Perimeter > 6 1/4 IN.)

CALIFORNIA RESIDENTIAL CODE – QUICK CODE REFERENCES

Exterior Stairway Illumination Requirements

Exterior stairway illumination* - Section R303.7

Glazing Adjacent to Stairways

Glazing adjacent to stairs* - Section R308.4.6

Glazing adjacent to the bottom stair landing* - Section R308.4.7

Guardrails

Guard requirements - Section R312.1

Where guards are required - Section R312.1.1

Guard height requirements* - Section R312.1.2

Opening limitations* - Section R312.1.3

Loads - Table R301.5

Handrails

Handrails - Section R311.7.8

Height* - Section R311.7.8.1

Continuity* - Section R311.7.8.2

Grip-size - Section R311.7.8.3

Loads - Table R301.5

Landings and Walking Surface

Landings for stairways* - Section R311.7.6

Stairway walking surface - Sections R311.7.7

Stairway Widths and Headroom

Stairway Width* - Section R311.7.1

Stairway Headroom* - Section R311.7.2

Stairway Treads, Risers and Nosing

Stair treads and risers - Section R311.7.5

Stair risers (rise)* - Section R311.7.5.1

Stair treads (run) - Section R311.7.5.2

Tread nosing* - Section R311.7.5.3

Attachment - Section R311.5.1

Wildland–Urban Interface (WUI) Area - Section R327.9.2

*Section includes exceptions.

A permit ([form HCD 50](#)) is required from HCD when a deck's landing exceeds 12 square feet and is in an HCD Mobilehome Park. [T25 CCR Section 1018\(d\)\(5\)](#).

Always refer to the actual and current text of applicable laws and regulations. The California Residential Code is available at www.bsc.ca.gov/codes. This document is not intended to be all-inclusive.

Unaltered existing stairways are subject to the requirements that were in effect during the original approval/installation.